

DWC.# SH REV.

REVISIONS

REV.	DESCRIPTION	DATE	APPROVED
A	RELEASE PER ECO# 11911	01/04/07	J. HECHT

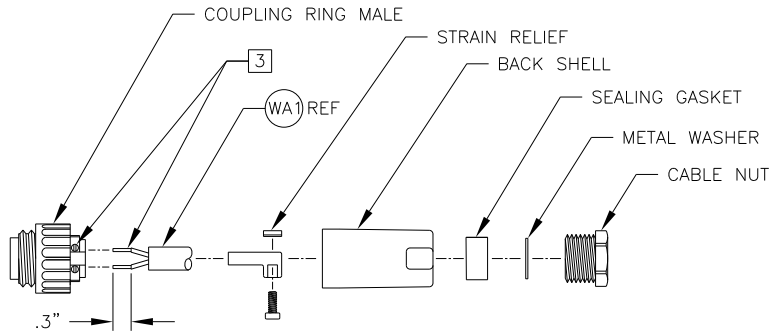

DETAIL A  
SCALE: 1:1

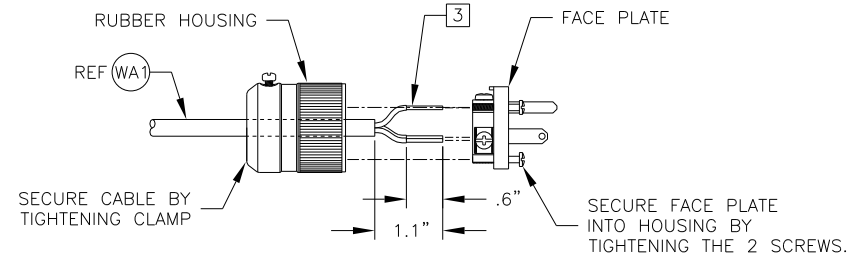

DETAIL B  
SCALE: 1:1

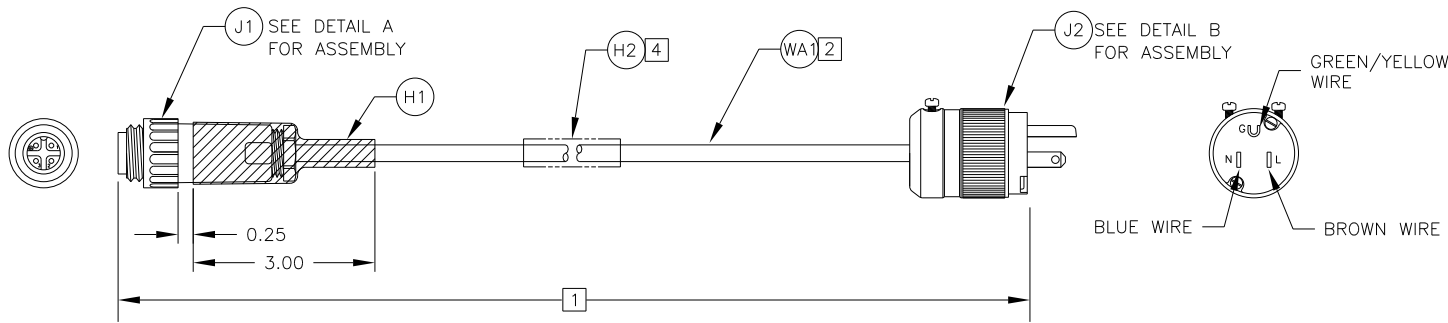

INTERCONNECT DIAGRAM		
FROM (ITEM J1)	TO (ITEM J2)	WIRES (ITEM WA1)
PIN 1	N/A	N/A
PIN 2	TERMINAL-N	BLUE
PIN 3	TERMINAL-L	BROWN
⊕	TERMINAL-G	GREEN/YELLOW

NOTES: (UNLESS OTHERWISE SPECIFIED)

- 1 DASH NUMBER EQUALS CABLE LENGTH IN FEET.
- 2 STRIP CABLE JACKET TO APPROPRIATE LENGTH ON BOTH ENDS
- 3 PRIOR TO INSTALLATION, STRIP WIRES FROM ITEM WA1 WITH PROPER STRIP TOOL, STRIP LENGTH TO BE APPROX .300 & .600 INCHES. DO NOT TIN WIRES. INSERT ONE END OF WIRE STRANDS INTO COUPLING RING AND OTHER END OF WIRE STRANDS INTO FACE PLATE TERMINALS AND SECURE WIRE STRANDS IN PLACE BY TIGHTENING SCREW CLAMP ASSEMBLY.



- 4 IDENTIFY CABLE WITH TERRASAT COMMUNICATIONS INC. PART NUMBER AND CURRENT REVISION LEVEL ON LABEL (ITEM H2).
- 5. FINISHED PART MUST BE RoHS COMPLIANT.

ITEM#	QTY	TERRASAT PART#	DESCRIPTION	MANUF. PART#
H2	1	395-10893-0001	LABEL, SELF LAMINATING, 1.0 X 2.25 X .75	TYCO/RAYCHEM, SB100225WE5
H1	3.0"	557-10662-0003	SHRINK TUBING W/ADHESIVE LINER, 4:1 RATIO, 1.25" BLK	DABURN, DAFLEX SM278
WA1	1	555-20993-0001	CABLE, INT'L HARMONIZED, 3x1.5mm SQ, H05VVF, PVC, YEL	INTERPOWER, 86020330
J2	1	533-20994-0001	CONNECTOR, AC PLUG, STRAIGHT BLADE, NEMA 5-15, BLK	INTERPOWER, 88030100
J1	1	533-10390-0001	CONNECTOR, CIRCULAR, W/STRAIN RELIEF, 3+PE, FEMALE	AMPHENOL, T3109 001

PARTS LIST

MATERIAL	SEE NOTES	UNLESS OTHERWISE SPECIFIED ALL DIMENSIONS ARE IN INCHES	<b>TERRASAT COMMUNICATIONS, INC.</b>	
FINISH	SEE NOTES	TOLERANCES ARE: XX ±.01 SURFACE FINISH XXX ±.005 ANGLES		
THIS DOCUMENT CONTAINS INFORMATION PROPRIETARY TO TERRASAT COMMUNICATIONS INC. WHICH IS EITHER COPYRIGHTED OR PATENT APPLIED FOR AND/OR PROTECTED BY TRADE SECRET LAWS. THIS DOCUMENT OR ANY PARTS THEREOF, MAY NOT BE USED, DISCLOSED OR REPRODUCED IN ANY FORM, BY ANY METHOD, OR FOR ANY PURPOSE WITHOUT THE EXPRESS WRITTEN PERMISSION OF TERRASAT COMMUNICATIONS INC.		DRAWN BY: S. LOW DATE: 01/04/07	<b>FABRICATION DRAWING, CABLE ASSY, AC, ODU PSU, AC PLUG, 3 WIRE</b>	
		APPROVED BY: J. HECHT DATE: 01/04/07	SIZE: B	DR# <b>FBD-20606-XXXX</b>
		CHANGED BY:	SCALE: 1/2	FILE: 206061A
		CHECKED BY:	REV A	
		DO NOT SCALE DRAWING	SHEET 1 OF 1	